

# Commercial Vehicle Systems Trailer Products

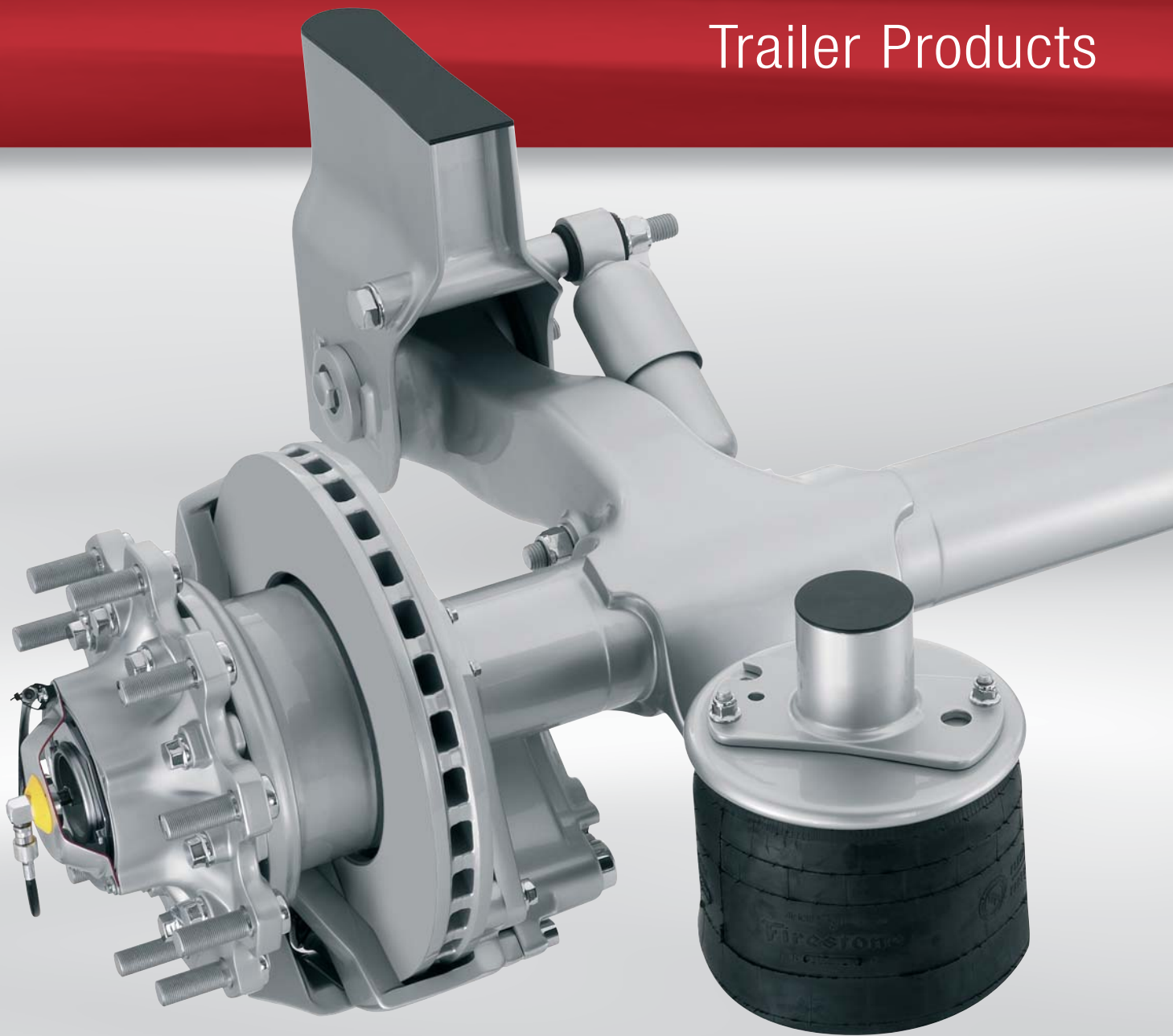

ArvinMeritor has become a global leader in trailer components by engineering a complete line of low-maintenance running gear components and backing them with a commitment to quality, service and genuine OEM-quality aftermarket parts.

With products ranging from axles, air suspensions and tyre inflation systems, to a complete line of foundation brakes, anti-lock braking systems, wheel-end systems, automatic slack

adjusters, and hubs and drums, ArvinMeritor is the only company with a major presence in both North American and European markets. The company is also South America's largest trailer brake manufacturer.



**MERITOR**<sup>®</sup>

an **ArvinMeritor** brand



### Compatico Trailer System

The ROR® Compatico is a new trailer, axle, brake and suspension system developed jointly between ArvinMeritor and Renault Trucks. Custom designed to ensure compatibility between the trailer and truck, the Compatico allows the entire vehicle braking system to work in unison, extending pad life, reducing premature disc wear and minimising vehicle downtime.

- Utilises D-ELSA2 air disc brake
- Guided twin pistons
- Fully sealed sliding system
- Greatly expanded support network for Compatico products
- Access to 1450 Renault truck dealers throughout Europe
- 24 Hour breakdown and recovery service via ROR Network for Renault Premium/Magnum drivers



New for  
**MAY 2007**

### ELSA225L Trailer Axle

- Max torque up to 27 kNm
- Variable ratio
- Guided twin tappets for optimum load distribution
- Internally synchronised tappets with travel stops for trouble free servicing
- Modular construction for improved part commonality and optimised installation
- Part of the extended ELSA family which delivers
  - High-durability
  - Improved double sealing
  - Reduced weight
  - High stiffness for low air consumption

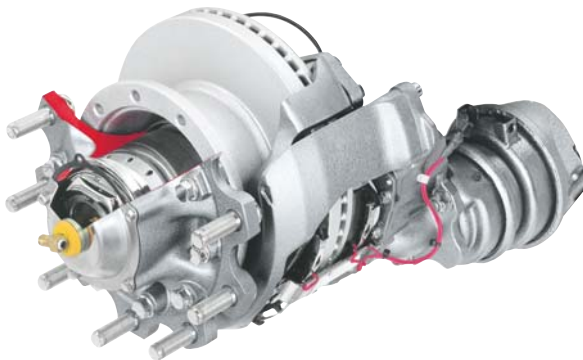

### LMC195 Trailer Axle

Fitted with Meritor® ELSA 195 air disc brakes the ROR® LMC195 trailer axle is also configured to accept the optional ROR® Brake Alert System that gives safety critical visual feedback to the driver on the condition of the brake pads.

- No-Maintenance Cartridge Hub Bearing
- 8 and 10 Stud variants
- Optional ROR Tyre Inflation System

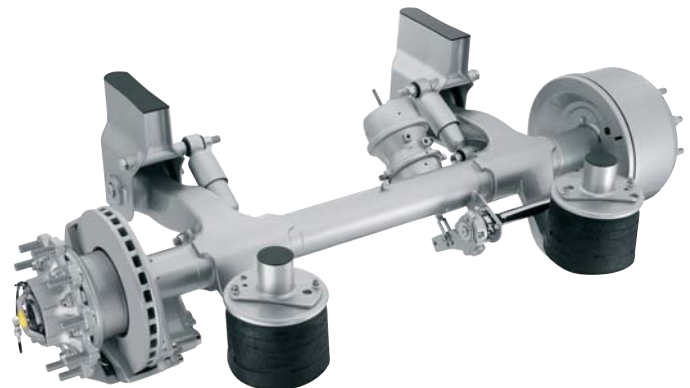

### ROR CS Air Suspension

ROR Meritor are introducing a new concept in air suspension design, production and application. The proven quality and reliability at every stage of production of the CS range is backed with rigorous quality control and inspection to the same high standards of ROR axles and brakes. This results in the optimum running gear combination. The CS suspension accommodates both disc and drum brakes and is fully compatible with ROR axles.

- 200mm to 500mm ride heights
- Direct trailing arm to axle joint – no 'U' Bolts
- Cast steel 'C' section trailing arms
- Pivot eye tracking as standard
- Composite piston airspring
- Mounts directly to a 80mm chassis flange width

ArvinMeritor B.V.  
Antareslaan 47  
2132 JE Hoofddorp  
Netherlands  
Tel: +31 23 56 90 300  
Fax: + 31 23 56 15 829  
www.arvinmeritor.com

Descriptions and specifications were in effect at the time of publication and are subject to change without notice or liability.

© Copyright 2007 ArvinMeritor All rights Reserved  
Issued 04/2007 Publication 4.112.3

**ArvinMeritor**™